

PORT FRONT FUSELAGE

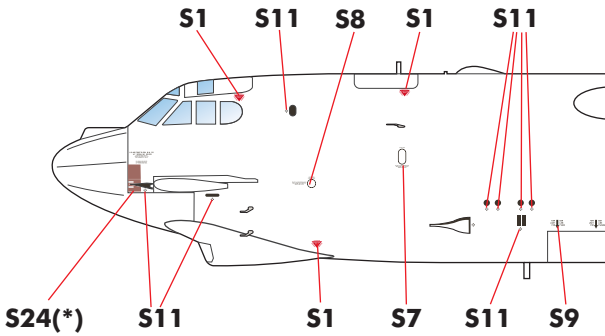

STARBOARD FRONT FUSELAGE

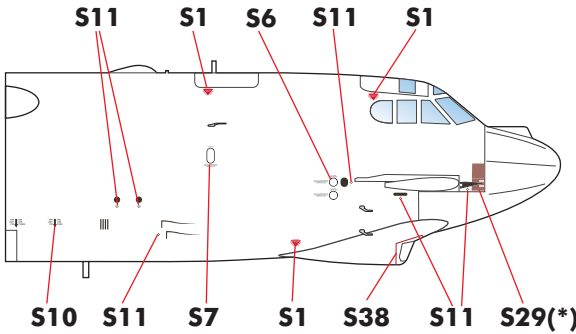

TOP FRONT FUSELAGE

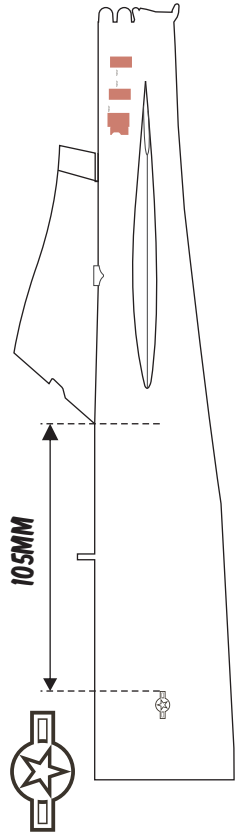
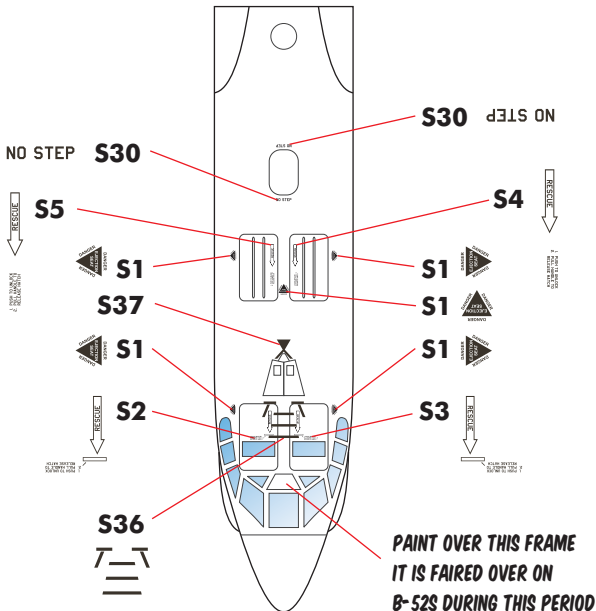

LOCATION OF NATIONAL INSIGNIA

USE RED REFUELING MARKINGS FOR ALL B-52 OPTIONS ON THIS SHEET

WING MARKINGS

PORT WING SHOWN - MIRROR FOR OTHER WING

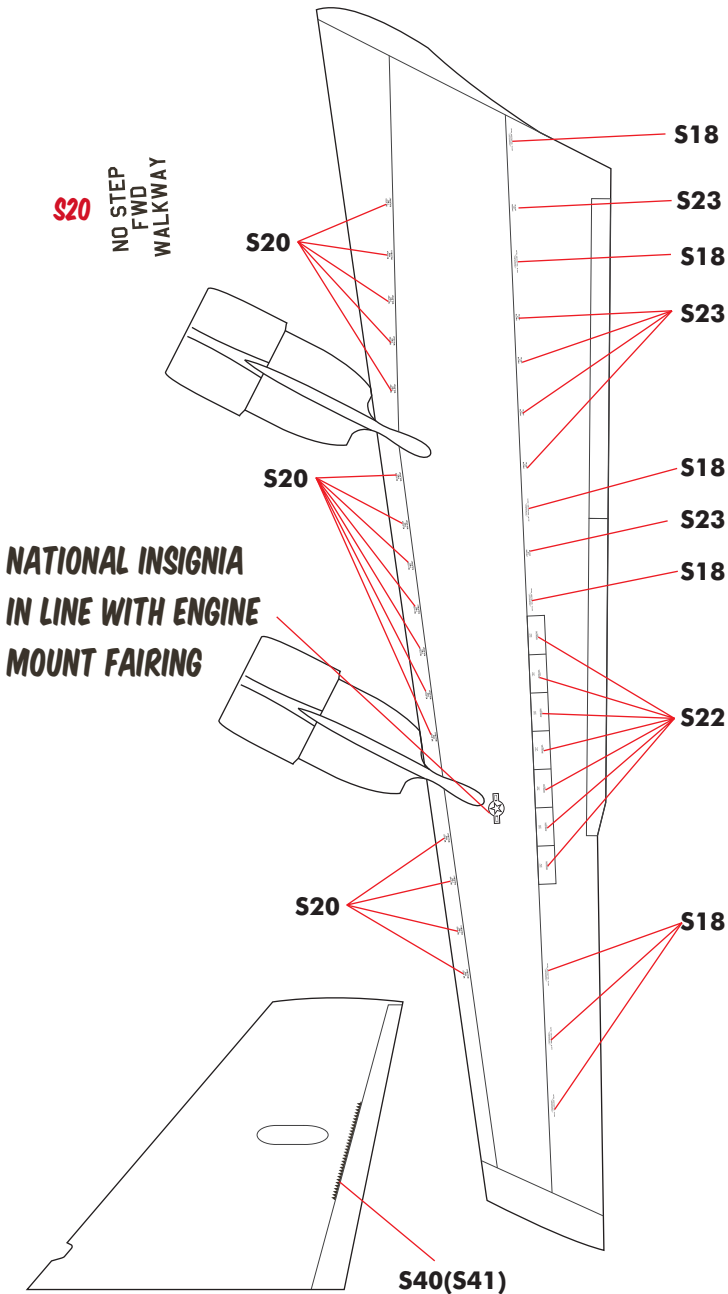

S20
NO STEP
FWD
WALKWAY

**NATIONAL INSIGNIA
IN LINE WITH ENGINE
MOUNT FAIRING**

NOTE ORIENTATIONS

S23
NO STEP
AFT
WALKWAY

S18
CAUTION - HONEYCOMB PANEL - NO STEP
PANEL NOT DESIGNED FOR CONCENTRATED LOADS
DO NOT DROP TOOLS OR OTHER ARTICLES

S22
CAUTION
STAND CLEAR DURING
SPOILER OPERATION
NO STEP
AFT
WALKWAY

S40(S41)

REAR FUSELAGE

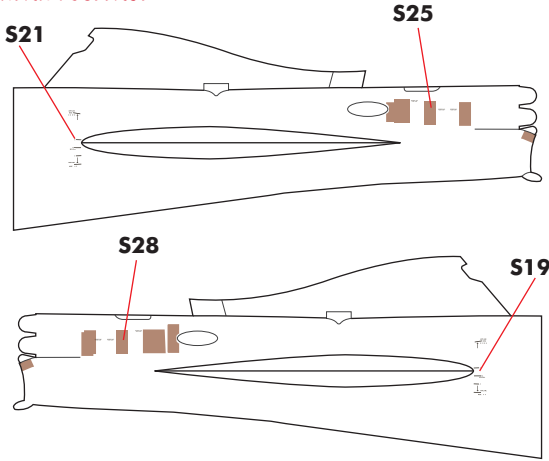

REAR FUSELAGE - TOP VIEW (SIMPLIFIED)

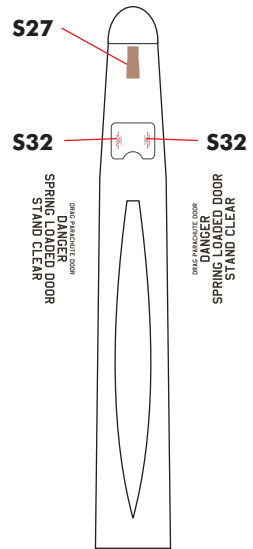

DROP TANKS

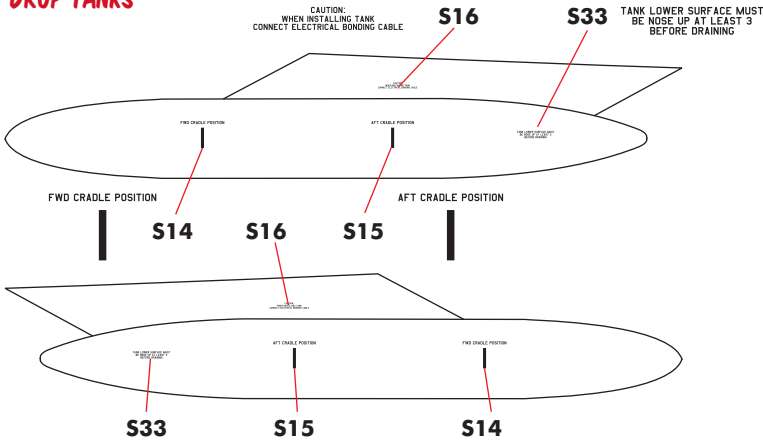

BOMB BAY DOORS

